

## Chapter 1 Matter in Our Surroundings:

**Question 1. Which of the following are matter?**

**Chair, air, love, smell, hate, almonds, thought, cold, cold-drink, smell of perfume.**

**Answer:** Chair, air, almonds, and cold-drink.

**Question 2. Give reasons for the following observation:**

**The smell of hot sizzling food reaches you several meters away, but to get the smell from cold food you have to go close.**

**Answer:** The smell of hot sizzling food reaches several meters away, as the particles of hot food have more kinetic energy and hence the rate of diffusion is more than the particles of cold food.

**Question 3. A diver is able to cut through water in a swimming pool. Which property of matter does this observation show?**

**Answer:** A diver is able to cut through water in a swimming pool. This shows that the particles of water have intermolecular space and has less force of attraction.

**Question 4. What are the characteristics of the particles of matter?**

**Answer.** The characteristics of the particles of matter are:

- (1) Particles have intermolecular space.
- (2) Particles have intermolecular force.
- (3) Particles of matter are moving continuously.

### Class 9 Science NCERT Textbook – Page 6

**Question 1. The mass per unit volume of a substance is called density.**

**(density = mass/volume).**

**Arrange the following in order of increasing density: air, exhaust from chimneys, honey, water, chalk, cotton and iron.**

**Answer:** Increasing density:

air < exhaust from chimneys < cotton < water < honey < chalk < iron.

**Question 2. (a) Tabulate the differences in the characteristics of states of matter.**

**(b) Comment upon the following: rigidity, compressibility, fluidity, filling a gas container, shape, kinetic energy and density.**

**Answer:** (a) Difference in the characteristics of 3 states of matter.

Characteristics	Solid	Liquid	Gas
1. Shape	fixed shape	no fixed shape	no fixed shape
2. Volume	fixed volume	fixed volume	no fixed volume
3. Rigidity/fluidity	are rigid, cannot flow	can flow, not rigid	can flow, not rigid
4. Intermolecular force	maximum	less than solids	very less
5. Intermolecular space	very less	more than solids	maximum and less than gas
6. Compressibility	negligible	compressible	highly compressible

**(b) Comment on:**

**(i) Rigidity:** The tendency of a substance to retain/maintain their shape when subjected to outside force.

- (ii) **Compressibility:** The matter has intermolecular space. The external force applied on the matter can bring these particles closer. This property is called compressibility. Gases and liquids are compressible.
- (iii) **Fluidity:** The tendency of particles to flow is called fluidity. Liquids and gases flow.
- (iv) **Filling of a gas container:** Gases have particles which vibrate randomly in all the directions. The gas can fill the container.
- (v) **Shape:** Solids have maximum intermolecular force and definite shape. Whereas liquids and gases take the shape of container.
- (vi) **Kinetic energy:** The energy possessed by particles due to their motion is called kinetic energy. Molecules of gases vibrate randomly as they have maximum kinetic energy.
- (vii) **Density:** It is defined as mass per unit volume, the solids have highest density.

### Question 3. Give reasons

- (a) A gas fills completely the vessel in which it is kept.
- (b) A gas exerts pressure on the walls of the container.
- (c) A wooden table should be called a solid.
- (d) We can easily move our hand in air but to do the same through a solid block of wood we need a karate expert.

**Answer:** (a) The molecules of gas have high kinetic energy due to which they keep moving in all directions and hence fill the vessel completely in which they are kept.

(b) A gas exerts pressure on the walls of the container because the molecules of the gas are in constant random motion due to high kinetic energy. These molecules constantly vibrate, move and hit the walls of the container thereby exerting pressure on it.

(c) The molecules/particles of wooden table are tightly packed with each other, there is no intermolecular space, it cannot be compressed, it cannot flow, all these characteristics are of solid. So wooden table should be called a solid. ‘

(d) We can easily move our hand in air but to do the same through a solid block of wood we need a karate expert. It is because the molecules of air have less force of attraction between them and a very small external force can separate them and pass through it. But in case of solids, the molecules have maximum force of attraction, the particles are tightly bound due to this force. Hence large amount of external force is required to pass through solid.

### Question 4. Liquids generally have lower density as compared to solids. But you must have observed that ice floats on water. Find out why.

**Answer:** Ice is a solid but its density is lower than water due to its structure. The molecules in ice make a cage like structure with lot of vacant spaces, this makes ice float on water.

### Class 9 Science NCERT Textbook – Page 9

#### Question 1. Convert the following temperature to Celsius scale:

- (a) 300 K (b) 573 K

**Answer.** (a)  $300 - 273 = 27^{\circ}\text{C}$  (b)  $573 - 273 = 300^{\circ}\text{C}$

#### Question.2. What is the physical state of water at:

- (a)  $250^{\circ}\text{C}$  (b)  $100^{\circ}\text{C}$

**Answer:** (a)  $250^{\circ}\text{C}$  = gas (b)  $100^{\circ}\text{C}$  liquid as well as gas

#### Question 3. For any substance, why does the temperature remain constant during the change of state?

**Answer:** During the change of state of any matter heat is supplied to the substance. The molecules of this matter use heat to overcome the force of attraction between the particles, at this period of time, temperature remains constant. This extra heat is acquired by the molecules in the form of hidden heat called latent heat to change from one state of matter to the other state.

**Question 4. Suggest a method to liquefy atmospheric gases?**

**Answer:** The atmospheric gases are taken in a cylinder with piston fitted on it. By cooling and applying pressure on them, the gases can be liquefied.

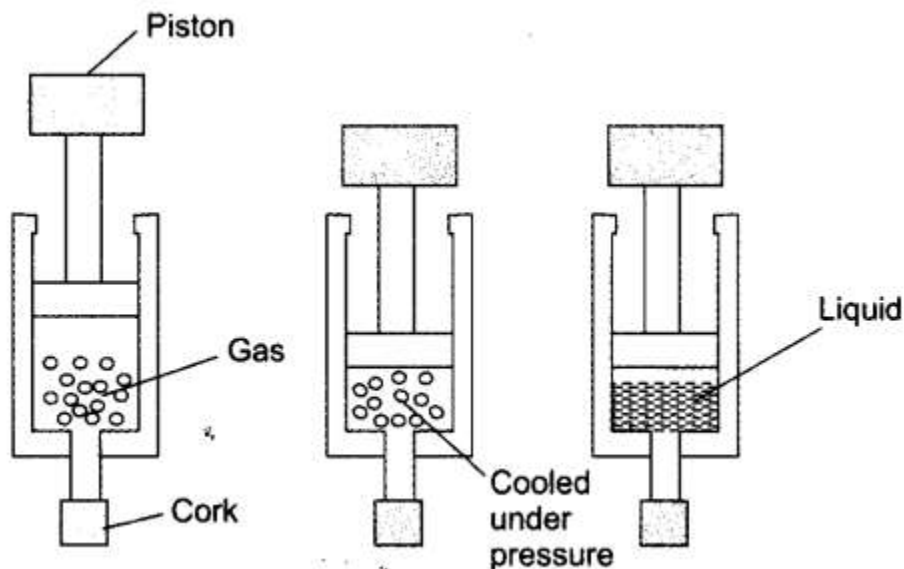

### NCERT Textbook Questions – Page 10

**Question 1. Why does a desert cooler cool better on a hot dry day?**

**Answer:** The outer walls of the cooler get sprinkled by water constantly. This water evaporates due to hot dry weather. Evaporation causes cooling of inside air of cooler. This cool air is sent in the room by the fan.

**Question 2. How does the water kept in an earthen pot (matka) become cool during summer?**

**Answer:** The earthen pot is porous with lot of pores on it, the water oozes out through these pores and the water gets evaporated at the surface of the pot thereby causing cooling effect. This makes the pot cold and the water inside the pot cools by this process.

**Question 3. Why does our palm feel cold when we put some acetone or petrol or perfume on it?**

**Answer:** Acetone, petrol or perfume evaporate when they come into contact with air. The evaporation causes cooling sensation in our hands.

**Question 4. Why are we able to sip hot tea or milk faster from a saucer rather than a cup?**

**Answer:** Tea in a saucer has larger surface area than in a cup. The rate of evaporation is faster with increased surface area. The cooling of tea in saucer takes place sooner than in a cup. Hence we are able to sip hot tea or milk faster from a saucer rather than a cup.

**Question 5. What type of clothes should we wear in summer?**

**Answer:** We should wear light coloured cotton clothes in summer. Light colour because it reflects heat. Cotton clothes because it has pores in it, which absorbs sweat and allows the sweat to evaporate faster thereby giving cooling effect.

### Questions From NCERT Textbook for Class 9 Science

**Question 1. Convert the following temperatures to the Celsius scale.**

(a) 293 K (b) 470 K.

**Answer:** (a) 293 K into °C

$$293 - 273 = 20^{\circ}\text{C}$$

(b) 470 K into °C  $470 - 273 = 197^{\circ}\text{C}$

**Question 2. Convert the following temperatures to the Kelvin scale.**

**(a) 25°C (b) 373°C.**

**Answer:** (a) 25°C into K

$$25 + 273 = 298 \text{ K}$$

(b) 373°C into K  $373 + 273 = 646 \text{ K}$

**Question 3. Give reason for the following observations.**

**(a) Naphthalene balls disappear with time without leaving any solid.**

**(b) We can get the smell of perfume sitting several metres away.**

**Answer:** (a) Naphthalene balls disappear with time without leaving any solid, because naphthalene balls sublime and directly changes into vapour state without leaving any solid.

(b) We can get the smell of perfume sitting several metres away because perfume contain volatile solvent and diffuse faster and can reach people sitting several metres away.

**Question 4. Arrange the following substances in increasing order of forces of attraction between the particles—water, sugar, oxygen.**

**Answer:** Oxygen  $\rightarrow$  water  $\rightarrow$  sugar.

**Question 5. What is the physical state of water at—**

**(a) 25°C (b) 0°C (c) 100°C**

**Answer:** (a) 25°C is liquid (b) 0°C is solid or liquid

(c) 100°C is liquid and gas

**Question 6. Give two reasons to justify**

**(a) water at room temperature is a liquid.**

**(b) an iron almirah is a solid at room temperature.**

**Answer:** (a) Water at room temperature is a liquid because its freezing point is 0°C and boiling point is 100°C.

(b) An iron almirah is a solid at room temperature because melting point of iron is higher than room temperature.

**Question 7. Why is ice at 273 K more effective in cooling than water at the same temperature?**

**Answer:** Ice at 273 K will absorb heat energy or latent heat from the medium to overcome the fusion to become water. Hence the cooling effect of ice is more than the water at same temperature because water does not absorb this extra heat from the medium.

**Question 8. What produces more severe burns, boiling water or steam?**

**Answer:** Steam at 100°C will produce more severe burns as extra heat is hidden in it called latent heat whereas the boiling water does not have this hidden heat.

**Question 9. Name A, B, C, D, E and F in the following diagram showing change in its state**

**Answer:** A  $\rightarrow$  Liquefaction/melting/fusion B  $\rightarrow$  Vapourisation/evaporation C  $\rightarrow$  Condensation D  $\rightarrow$  Solidification E  $\rightarrow$  Sublimation F  $\rightarrow$  Sublimation

